

MINI Screen MS28

MAITEK Mini-Screen has been designed to be able to select or clean many types of materials including excavated land, rubble, gravel and asphalt, transforming these products from landfill material into recyclable goods.

Extremely compact dimensions, lifting hooks and slides for forklifts incorporated together with a very low weight make it very easy to transport and use, ensuring very high versatility.

The electrical panel on board with industrial socket makes it completely autonomous, eliminating commissioning times. The switchboard can be supplied with either a standard 400V THREE-PHASE power supply or a 230V-SINGLE-PHASE (OPTIONAL) power supply, increasing both versatility and ease of use.

The transversal belt (version MS28-S) allows the separation of the 3 screened materials.





Model	MS28	MS28-S
Mesh dimensions (m)	1,4 x 2,0	1,4 x 2,0
Capacity (T/h) *	50-80	50-80
Electrical power (kW)	1,5	1,5 + 0,75
Overall dimensions (m)	1,7 x 3,2 H=2,7	2,4 x 4,1 H=2,7
Weight (kg)	1550	1900

* The performances are strongly influenced by the type of treated material.

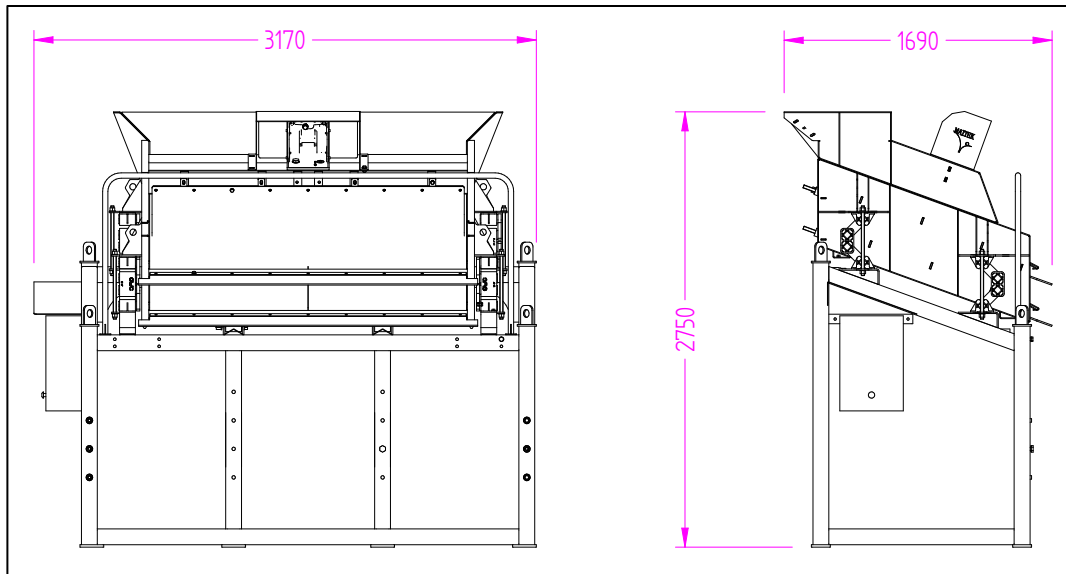

MS28

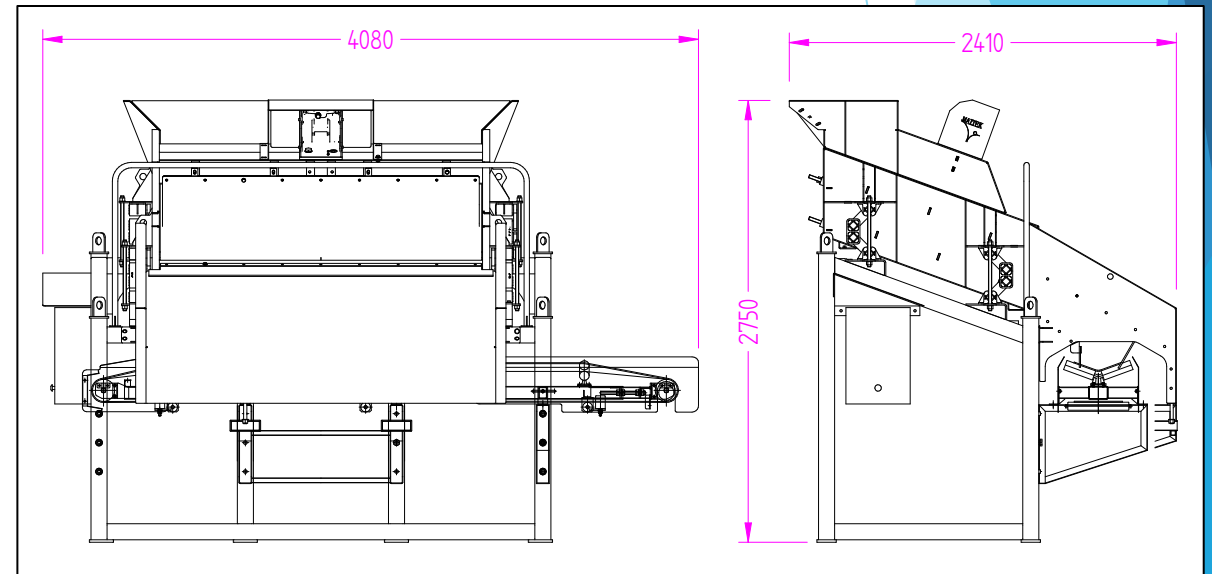

MS28-S