

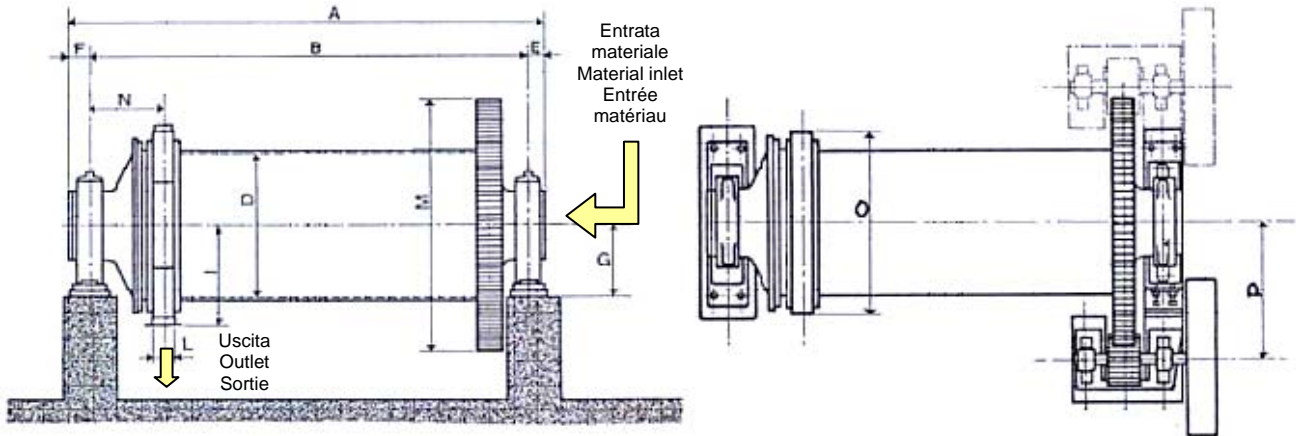

MMBL

MULINO A BARRE A SCARICO LATERALE ROD MILL WITH LATERAL DISCHARGE GRANULATEUR A BARRES A DECHARGE LATERALE



Modello Model Modèle	Peso Weight Poids (Kg)	Produzione per sabbia di mm Output for sand of mm Production pour sable de mm (t/h)			Pezzatura alimentazione Feeding size Pièce alimentation (mm)	Carica barre Rod filling Charge barre (Kg)	Potenza Power Puissance (Kw)
		0-3	0-4	0-6			
MMBL 1600	17600	10---15	15---20	20---25	20	11000	90
MMBL 1800	23100	20---25	20---30	30---35	25	16400	132
MMBL 2150	34400	30---35	35---40	45---50	25	26500	200
MMBL 2400	54000	35---40	40---50	40---60	100	33000	315

Modello Model Modèle	A	B	D	E	F	G	I	L	M	N	O	P
MMBL 1600	4555	4230	1500	139	186	500	1000	145	2341	484	2060	1269
MMBL 1800	4715	4390	1800	142	183	545	1250	245	2720	550	2500	1480
MMBL 2150	5200	4860	2150	168	172	650	1400	245	3200	630	2730	1718
MMBL 2400	6200	6200	2400	182	186	1380	1800	245	2830	830	2830	1920

PRODUCT CURVES OF ROD MILLS WITH LATERAL DISCHARGE mod. "MMBL"

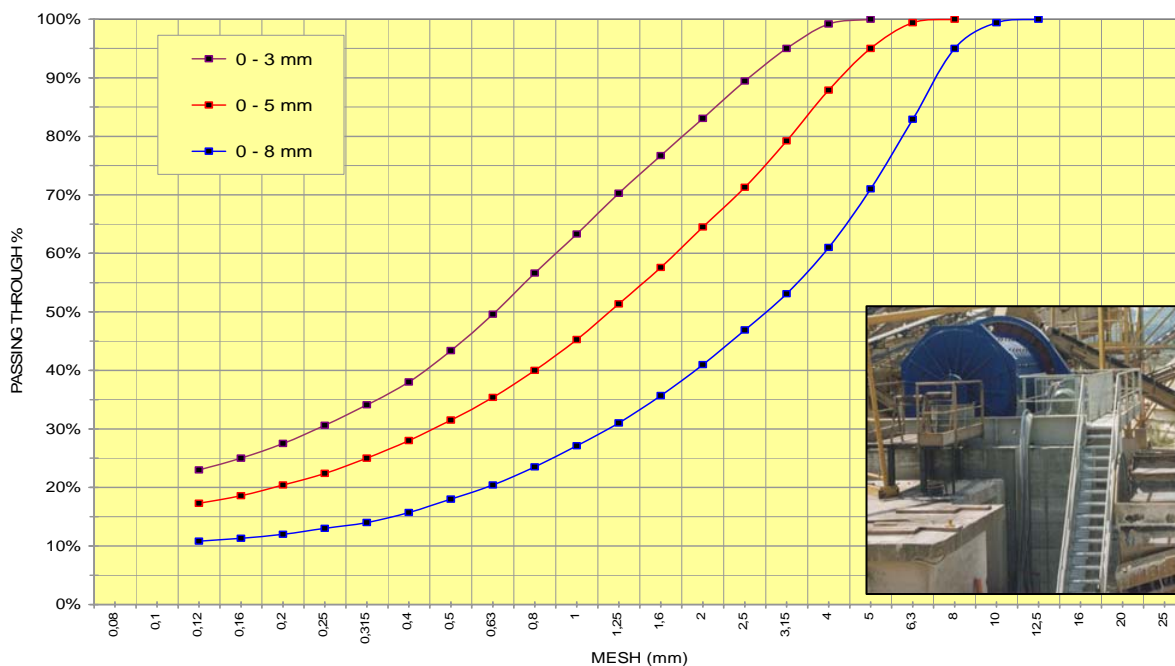

I DATI SOPRA RIPORTATI NON SONO IMPEGNATIVI E POSSONO SUBIRE VARIAZIONI SENZA PREAVVISO. THE ABOVE DATA ARE NOT BINDING AND THEY CAN BE ALTERED WITHOUT NOTICE.
LES DONNÉES SUS-INDIQUÉES NE COMPORTENT AUCUN ENGAGEMENT ET PEUVENT ÊTRE CHANGÉES SANS PRÉAVIS.